

SYNTECH I (HIGH POWER)

DASH MOUNT

Notes:

- A: For internal speaker operation, pins #5 and #6 are connected as shown.
- B: For external speaker operation, remove pins #5 and #6 along with the jumper wire. Using AMP Mate-N-Lok .140 male pins, the external speaker is connected to pins #4 and #6.
- C: For carrier squelch systems, or for using CTCSS operation where the "Monitor" button is to be used on the radio front panel, and mic hang-up box is not used, pins #2 and #3 are connected as shown.
- D: For CTCSS operation, using a mic hang-up box, remove the pins #2 and #3 along with the jumper wire. Using AMP Mate-N-Lok .140 male pins, the mic hang-up box is connected to pins #2 and #3.

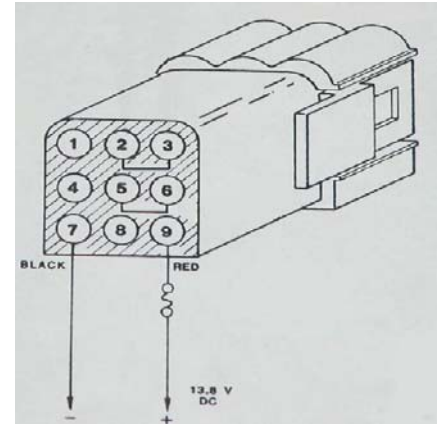

TRUNK MOUNT

RADIO UNIT

Notes:

- A: pins #5 and #6 are connected as shown, to route speaker audio to the control head.
- B: Other than the power connections, no other jumper is used.

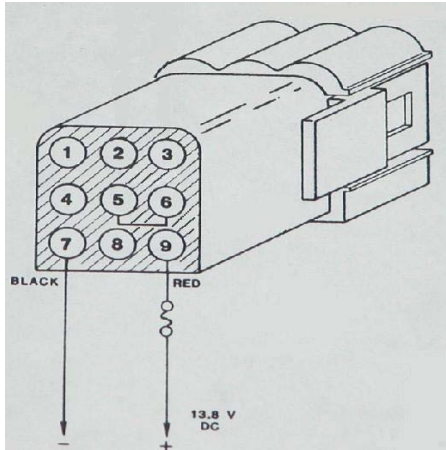

CONTROL HEAD

Notes:

- A: The external speaker is connected to pins #4 and #6, using Molex .093 male pins.
- B: Follow dash mount instructions for pins #2 and #3, above.

